



LINEAR SCREED DRAIN



PRODUCT SPECIFICATION GUIDE

SOLID
FLOOR

1.2 a

LINEAR SCREED DRAIN



Linear Screed Drain

By combining innovative design with the latest technology, our Linear Screed Drain offers designers the freedom to position a linear drain almost anywhere within the shower.

Utilising our unique **O-SEAL** trap we have achieved the shallowest possible drain, coupled with an almost infinite choice of grill length, height and finish, to meet the requirements of any project.

In addition we offer a simple floor build-up option, along with a range of waterproofing products, to provide a complete wetroom solution, all backed up by our Lifetime Guarantee.

1.2 a



INTRODUCTION

SOLID FLOOR



MINIMUM HEIGHT:
STANDARD
BRACKETS: 55mm
EXTRA SHALLOW
BRACKETS: 38mm



1.2 a

KEY FEATURES

The Linear Screed Drain has been developed specifically for concrete or screeded floors for use on concrete slabs, planks and block and beam floors.

The drain incorporates our unique **IO-SEAL** waterless trap technology which has been granted BBA approval and is supported with a lifetime guarantee.

The key feature of the Linear Screed Drain is its height, the total height from the base to the top of the trough being only 55mm, making it perfect for today's modern construction methods.

Available with one, two or three traps and a choice of stylish grill finishes the Linear Screed Drain will suit any application.

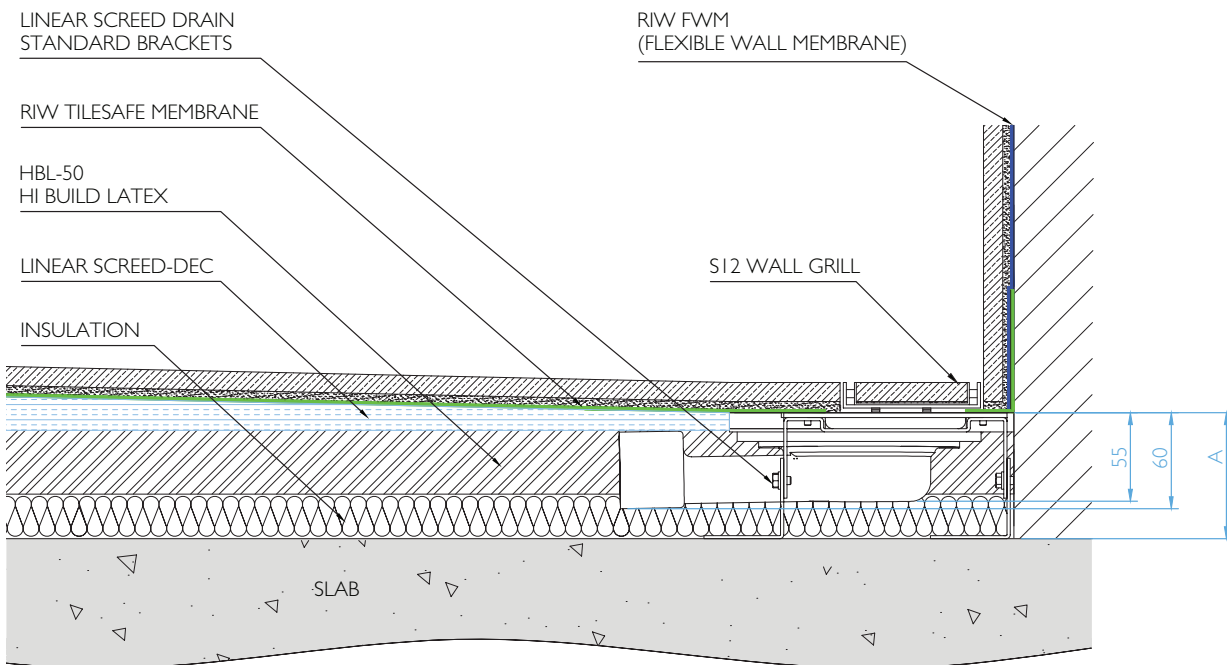

DIMENSION A : MIN. 55mm MAX. 88mm (Extension brackets available) drawn as 79mm.

LINEAR SCREED DRAIN

KEY FEATURES

- Minimum height 55mm with Standard Brackets
- Minimum height 38mm with Extra Shallow Brackets †¹
- BBA Approved
- Lifetime Guarantee
- **O-SEAL** Waterless Trap
- 360° Rotatable outlet
- Centre, left and right handed trap position
- Flow rate up to 70 L/min ‡²
- Height adjustable brackets
- Height adjustable grill
- Grill lengths up to 2000mm
- **FAST TRACK** Bespoke service - delivered in 3-4 days

†¹ Requires drain outlet to be recessed into the slab, refer to drawings on pages 18 & 19.
‡² See page 8 for full details.

HOW TO BUILD YOUR DRAIN

There are two components required to specify a Linear Screed Drain - the drain body and the grill.
To specify the drain body, select the required number of traps along with the bracket type.
Then simply choose the grill, selecting the desired type, length and finish.

DRAIN BODY



Number of traps

- Single Trap - flow rate up to 29 L/min
- Double Trap - flow rate up to 56 L/min
- Triple Trap - flow rate up to 70 L/min

See page 8 for full details

Bracket type

- Standard Height - adjustment 55mm-88mm
- Extra Shallow Height - adjustment 38mm-57mm[‡]

[‡] Extension brackets are available for floor depths above 88mm.
See page 9 for full details

GRILL



Grill type - Wall or Floor

- Floor Grill - for installation off the wall
- Wall Grill - positioned neatly up against the wall

See page 10 for full details

Grill length

- 15 Standard lengths
- Bespoke lengths from 600mm - 2000mm
- **FAST TRACK** Bespoke service - delivered in 3-4 days

See page 11 for full details

Grill finish

- 5 Stylish grill finishes

See page 13 for full details

1.2 a

NUMBER OF TRAPS

The unique **O-SEAL** waterless trap has been specially designed with a spring-loaded mechanism which keeps the trap sealed when not in use.

This ensures that even when left unused for prolonged periods the trap cannot dry out, making it ideal for situations where the shower is not in everyday use.

The smart design of the linear trough allows the waste position to be rotated through 360° enabling installation in most scenarios with ease.

- Easy to clean and replace trap
- Trap remains closed when not in use
- No siphoning of the trap due to other appliances
- No chance of smells or gases entering the room
- BBA approved
- Lifetime guarantee

I.2 a



O-SEAL Trap



29 L / min

Single Trap

- Flow rate up to 29 L/min †
- Centre trap position (shown)
- Left and right handed option also available
- Outlet position rotates through 360°



56 L / min

Double Trap

- Flow rate up to 56 L/min †
- For medium-high performance showers
- Outlet position rotates through 360°



70 L / min

Triple Trap

- Flow rate up to 70 L/min †
- For high performance showers
- Outlet position rotates through 360°

† Flow rates indicated are a guide only, based upon 42mm waste pipe and swept bends. See pages 16 & 17 for product codes.

BRACKET TYPE

The standard bracket allows the drain to be set as low as 55mm, with height adjustment up to 88mm.

Extension brackets are available for floor depths above 88mm - see below for details.

The extra shallow bracket allows the drain to be set as low as 38mm, with height adjustment up to 57mm.

This requires the drain outlet to be recessed into the slab - for details see drawing on pages 18 & 19.

STANDARD BRACKET

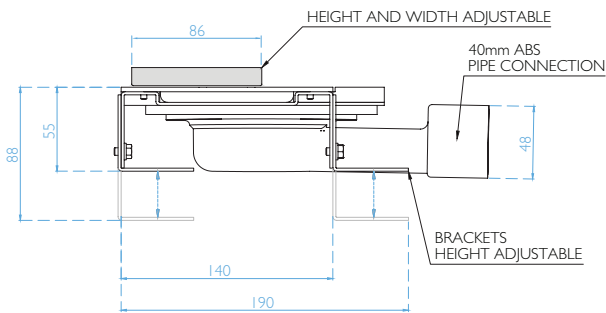

EXTRA SHALLOW BRACKET

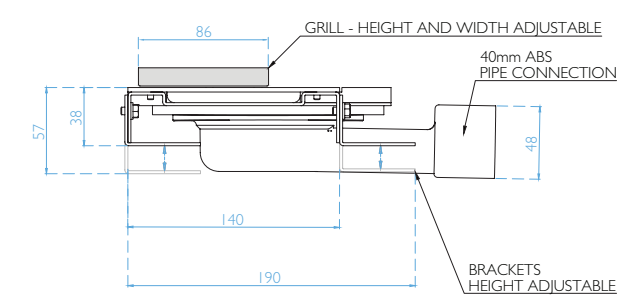

HEIGHT EXTENSION BRACKET

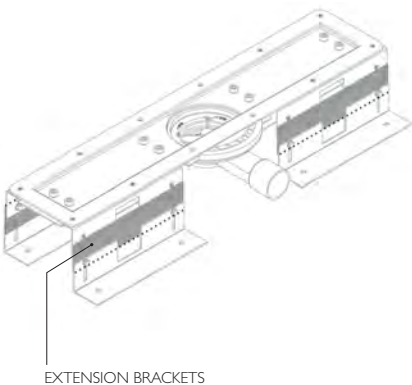

Use extension brackets where the required height of the drain body exceeds 88mm.

Each bracket will increase the height by 30mm, multiple brackets can be used if necessary.

See pages 16 & 17 for product codes.

GRILL TYPE - WALL OR FLOOR

There are two types of grill available with the Linear Screed Drain, both fit onto the drain body using 8 pre-set fixing points.

Both the Floor Grill and Wall Grill are independently height adjustable, enabling the grill to be positioned precisely to suit the tile thickness being used.

The final position of the Wall Grill is also independently width adjustable by up to 38mm, allowing the grill to be neatly positioned up against the wall tile, after the drain body has been installed, for a perfect finish every time.

All grills are manufactured in 316 grade stainless steel ensuring a stunning high quality durable finish.

FLOOR GRILL

The centre point of the Floor Grill is typically positioned 150mm from the wall, to create a two-way fall within the shower: **Grill width 58mm.**

WALL GRILL

The Wall Grill is positioned neatly up against the wall, to create a one-way fall within the shower: **Grill width 86mm.**

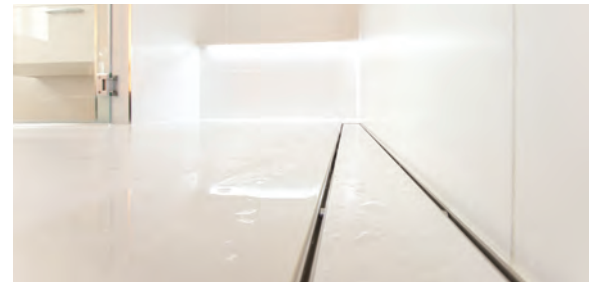
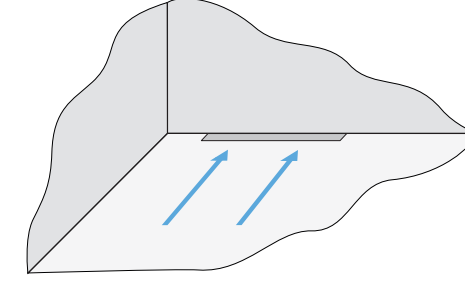
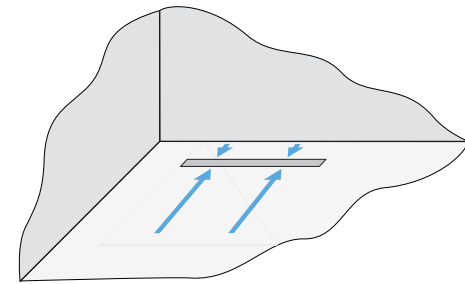
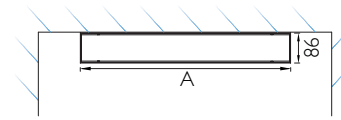
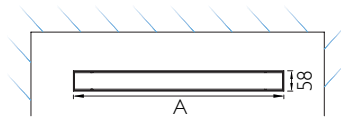

HEIGHT ADJUSTMENT

The Floor Grill is independently height adjustable in 1mm increments to suit different tile thicknesses.

The Wall Grill is independently height adjustable in 1mm increments to suit different tile thicknesses. The final position of the Wall Grill is also independently width adjustable by up to 38mm.

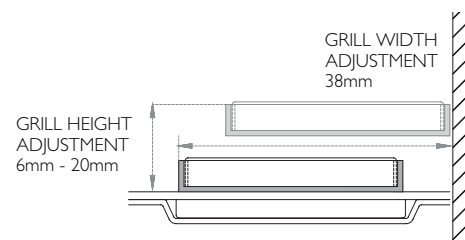
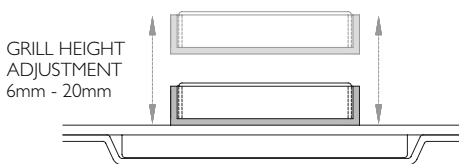

See pages 16 & 17 for product codes.

GRILL LENGTH

All grill types are offered in 15 standard lengths ranging from 600mm to 2000mm, with the majority available from stock on a next day delivery service.^{‡1}

Where a standard grill length is not suitable we offer a **FAST TRACK** bespoke design service, manufactured and delivered in as little as 3-4 days. See below for further details.

The drain body is always installed first, prior to the application of the waterproofing membrane, with the grill installed at the point of tiling.

Regardless of the length of grill, the drain body always remains the same at 660mm. Where the grill length exceeds 660mm the ends of the grill overhang the drain body and are supported with tile adhesive - see image below.

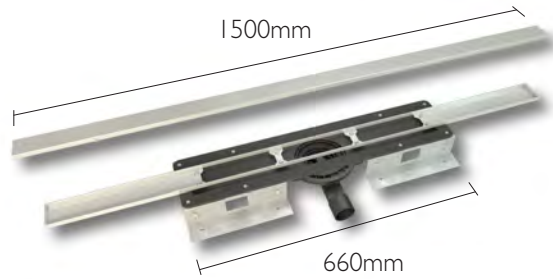
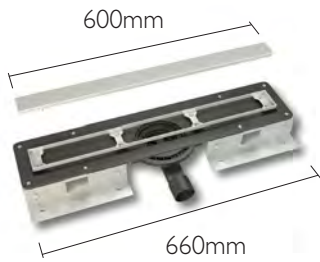

The following standard grill lengths are available:

- 600mm
- 700mm
- 800mm
- 900mm
- 1000mm
- 1100mm
- 1200mm
- 1300mm
- 1400mm
- 1500mm
- 1600mm
- 1700mm
- 1800mm
- 1900mm
- 2000mm

^{‡1} Excludes grill types B & C greater than 1500mm.

For grill types S & F greater than 1500mm; the Insert is supplied in two equal sections.

Offset grill position available as a bespoke - see below for details.

FAST TRACK BESPOKE

Where a standard grill length is not sufficient to meet the requirements of a project, such as when designing the drain to fit exactly between two walls, a bespoke length may be required.

We understand the exact grill length required may not be known until the shower has been tiled, therefore to meet such requirements we offer a unique **FAST TRACK** production service, where we can manufacture and deliver a bespoke length grill in 3-4 days.

We can achieve this due to the unique design of our drain, with the drain body supplied separately, and the grill to follow.

- Any length grill between 600mm-2000mm
- Manufactured and delivered in 3-4 days.
- Grill types A, S8, S12, S20 & F
- No drawing required ^{‡2}

^{‡2} Subject to drain body being installed centrally within the shower area.

BESPOKE GRILL DESIGN

We also offer a bespoke design service where we can manufacture a grill to a specific width or height, or to a completely unique design, usually within 2-3 weeks. Please contact our technical team for further information.

Wall to wall grill

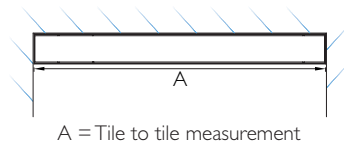

Where a wall to wall grill finish is required it is recommended to take a measurement on-site from the face of the wall tiles, therefore ensuring there are no gaps either side of the grill. The grill is manufactured and delivered in 3-4 days using our **FAST TRACK** grill service.

See pages 16 & 17 for product codes.

SOLID
FLOOR

1.2 a

LINEAR SCREED DRAIN

FRAMELESS GRILL

With only a shadow gap visible around the perimeter of the drain, the stunning Frameless Grill ensures water drains effortlessly away, providing a sleek, contemporary finish to any room.

Frameless design matches all brassware finishes.

GRILL FINISH

Ultimately the grill finish is the only visible element of our wetroom system and as such, is often the defining factor of the overall design.

From the contemporary Stone-Infill or ultra-stylish Frameless, to the simplicity of the Brushed stainless steel, we have a grill finish to complement any design style.

We manufacture all of our grills using only 316 marine grade stainless steel, ensuring a stunning high quality durable finish, complete with our Lifetime Guarantee.

The grill insert is easily removed for cleaning and maintenance, using the key provided with the grill.



BRUSHED STAINLESS STEEL

- Choice of designs in a metallic finish.

Type A - Solid

With a 5mm gap around the grill for a sleek stylish finish.

Type A



Type B - Slotted

Holes with a brushed stainless steel finish.

Type B



Type C - Square

Designed with a brushed stainless steel finish.

Type C



STONE-INFILL

- Allows a section of matching stone or tile to be inserted.

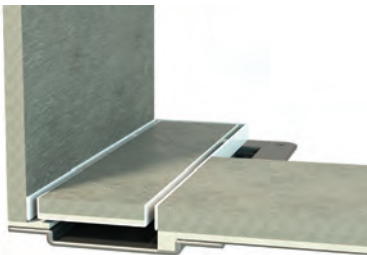

Type S8 - Stone-Infill ‡¹

Suits 6-8mm stone thickness.

Type S8

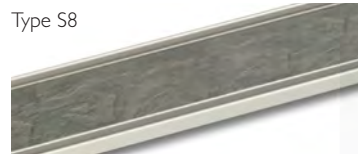

Type S12 - Stone-Infill ‡¹

Suits 10-12mm stone thickness.

Type S12



Type S20 - Stone-Infill ‡¹

Suits 18-20mm stone thickness.

Type S20

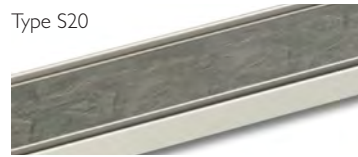

FRAMELESS

- Ensures a stunning almost invisible finish, using a section of matching stone or tile. Frameless design matches all brassware finishes.

Type F - Frameless Grill ‡¹

Suits any stone thickness.

Type F



Stock lengths 600mm - 2000mm. Bespoke lengths manufactured and delivered in as little as 3-4 days.

All grill finishes are kept in stock, see page 11-12 for available lengths and details of our bespoke manufacturing service.

See pages 16 & 17 for product codes.

‡¹ For grill types S & F greater than 1500mm, the insert is supplied in two equal sections. Suitable for stone and porcelain tiles only.

1.2 a

WETROOM COMPONENTS

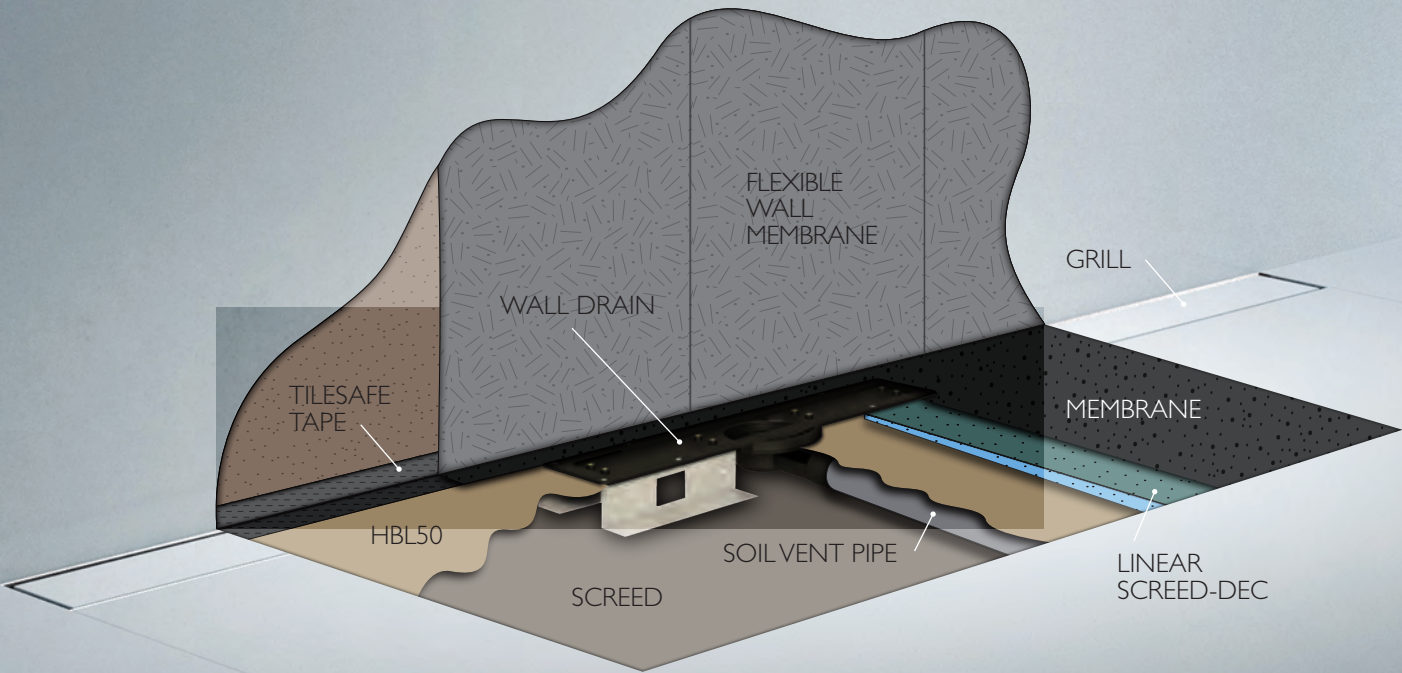

FLOOR BUILD-UP & WATERPROOFING

LINEAR SCREED-DEC

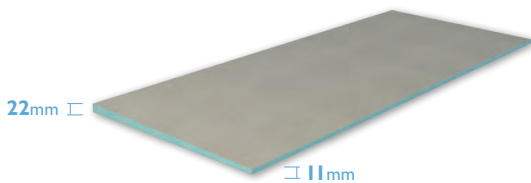

The Linear Screed-Dec is a pre-formed tapered board which removes the uncertainty of forming a fall within the screed in the shower area by hand.

Each board has a pre-engineered one-way fall, providing a guaranteed consistent gradient every time - see section 1.3 for full details.

HBL-50



HBL-50 is a hi-build wetrooms levelling compound specifically designed to provide a sound and stable base for the Linear Screed-Dec, while at the same time allowing for any on-site tolerances - see section 1.3 for full details.

1.2 a

WATERPROOFING

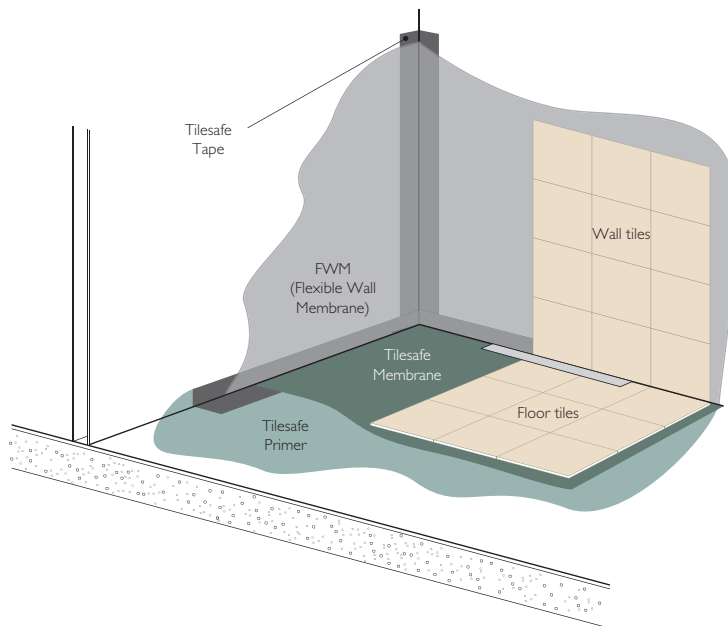

Waterproofing is one of the key elements of any wetroom, ensuring the room remains watertight at all times.

To ensure your entire project is fully covered by our Lifetime Guarantee we have developed a range of unique waterproofing solutions. These are specifically designed and guaranteed to work with our Linear Screed Drain, to provide a complete solution and total peace of mind.







- Floor and wall membrane
- De-coupling properties
- Acoustic properties
- Quick and easy to apply
- Lifetime Guarantee

See Section 3 for full details.

PRODUCT CODES - DRAIN BODY









DRAIN BODY WITH STANDARD BRACKETS





TYPE	DRAIN & FLOW RATE	TRAPS	CODE
 <p>Min 55mm Max 88mm</p>	 29 L / min	1: Centre	LSD-1C/ST
	 29 L / min	1: Right	LSD-1R/ST
	 29 L / min	1: Left	LSD-1L/ST
	 56 L / min	2	LSD-2/ST
	 70 L / min	3	LSD-3/ST

Extension brackets available to increase maximum height. Please see below.

DRAIN BODY WITH EXTRA SHALLOW BRACKETS

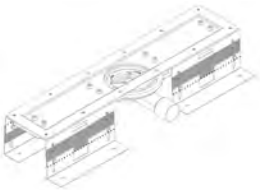
TYPE	DRAIN & FLOW RATE	TRAPS	CODE
 <p>Min 38mm Max 57mm</p>	 29 L / min	1: Centre	LSD-1C/ES
	 29 L / min	1: Right	LSD-1R/ES
	 29 L / min	1: Left	LSD-1L/ES
	 56 L / min	2	LSD-2/ES
	 70 L / min	3	LSD-3/ES

HEIGHT EXTENSION BRACKETS

TYPE	BRACKET TYPE	SUITABLE FOR	CODE
		Single Trap Centre (LSD-1C/ST)	LSD-1C/EXT
		Single Trap Handed (LSD-1R/ST or LSD-1L/ST)	LSD-1H/EXT
		Double Trap (LSD-2/ST)	LSD-2/EXT
		Triple Trap (LSD-3/ST)	LSD-3/EXT

Use extension brackets to increase the height of the standard drain above 88mm. Each bracket will increase the height by 30mm, multiple brackets can be used if necessary.

PRODUCT CODES - GRILL



SOLID FLOOR

WALL GRILL

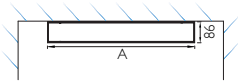

LENGTH	CODE	GRILL FINISH
600mm	SWG-600/-	Add code for Grill Finish:
700mm	SWG-700/-	
800mm	SWG-800/-	
900mm	SWG-900/-	
1000mm	SWG-1000/-	
1100mm	SWG-1100/-	
1200mm	SWG-1200/-	
1300mm	SWG-1300/-	
1400mm	SWG-1400/-	
1500mm	SWG-1500/-	
1600mm † ^{1,2}	SWG-1600/-	
1700mm † ^{1,2}	SWG-1700/-	
1800mm † ^{1,2}	SWG-1800/-	
1900mm † ^{1,2}	SWG-1900/-	
2000mm † ^{1,2}	SWG-2000/-	
FAST TRACK Bespoke † ³	SWG-FT/-	
Bespoke † ^{1,2}	SWG-BES/-	

Stone-Infill options:

- S8** = Suits 6-8mm tile thickness
- S12** = Suits 10-12mm tile thickness
- S20** = Suits 18-20mm tile thickness
- F** = Suits any tile thickness

Brushed stainless steel options:

- A** = Solid
- B** = Slotted
- C** = Square

See p13 for full details.

Example:

Grill Type - Grill Length / Grill Finish
SWG - 1100 / S20

1.2 a

FLOOR GRILL

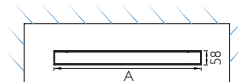

LENGTH	CODE	GRILL FINISH
600mm	SFG-600/-	Add code for Grill Finish:
700mm	SFG-700/-	
800mm	SFG-800/-	
900mm	SFG-900/-	
1000mm	SFG-1000/-	
1100mm	SFG-1100/-	
1200mm	SFG-1200/-	
1300mm	SFG-1300/-	
1400mm	SFG-1400/-	
1500mm	SFG-1500/-	
1600mm † ^{1,2}	SFG-1600/-	
1700mm † ^{1,2}	SFG-1700/-	
1800mm † ^{1,2}	SFG-1800/-	
1900mm † ^{1,2}	SFG-1900/-	
2000mm † ^{1,2}	SFG-2000/-	
FAST TRACK Bespoke † ³	SFG-FT/-	
Bespoke † ^{1,2}	SFG-BES/-	

Stone-Infill options:

- S8** = Suits 6-8mm tile thickness
- S12** = Suits 10-12mm tile thickness
- S20** = Suits 18-20mm tile thickness
- F** = Suits any tile thickness

Brushed stainless steel options:

- A** = Solid
- B** = Slotted
- C** = Square

See p13 for full details.

Example:

Grill Type - Grill Length / Grill Finish
SFG - 1100 / S20

†¹ For grill types B & C: 2-3 week lead-time.

†² For grill types S & F greater than 1500mm, the insert is supplied in two equal sections.

†³ Fast track service: Manufactured and delivered in 3-4 days, maximum length 2000mm.

TYPICAL DETAIL WITH WALL GRILL

STANDARD HEIGHT BRACKETS

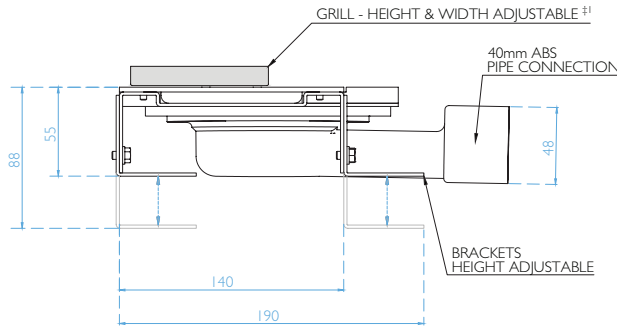

EXTRA SHALLOW HEIGHT BRACKETS

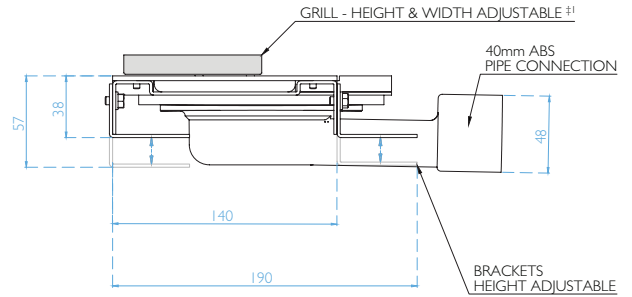

†¹ See page 10 for details.

WALL GRILL WITH STANDARD BRACKETS

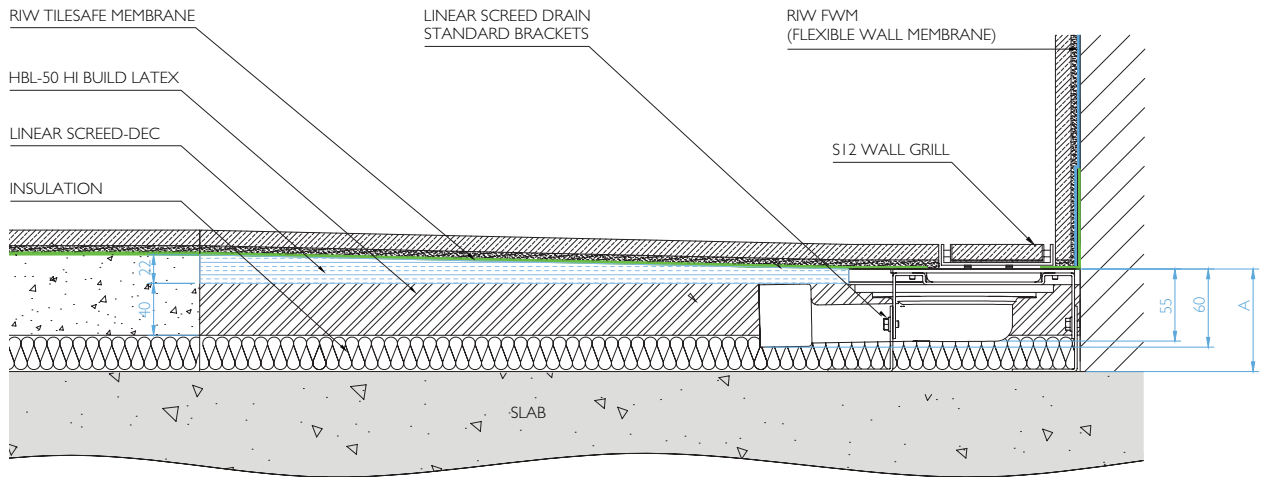

DIMENSION A : MIN. 55mm MAX. 88mm (Extension brackets available) drawn as 79mm.

WALL GRILL WITH EXTRA SHALLOW BRACKETS

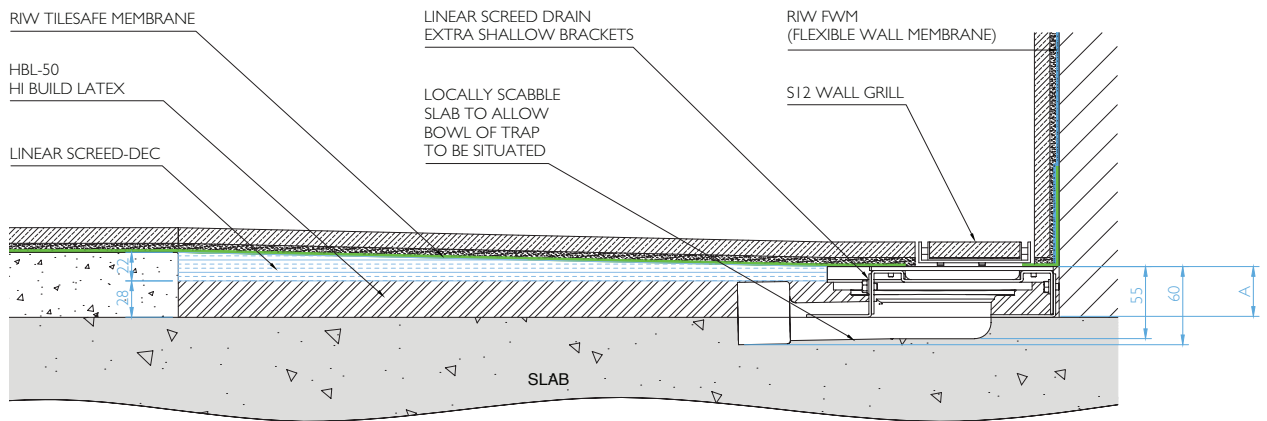

DIMENSION A : MIN. 38mm MAX. 57mm (Extension brackets available) drawn as 39mm.

1.2 a

LINEAR SCREED DRAIN

TYPICAL DETAIL WITH FLOOR GRILL

STANDARD HEIGHT BRACKETS

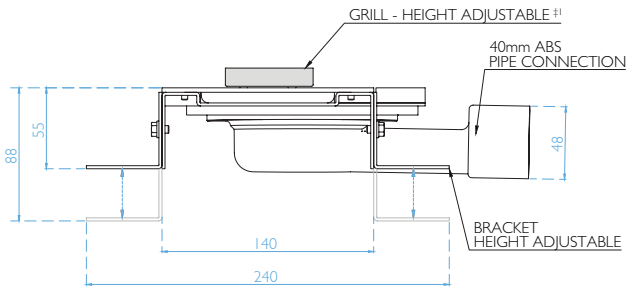

EXTRA SHALLOW HEIGHT BRACKETS

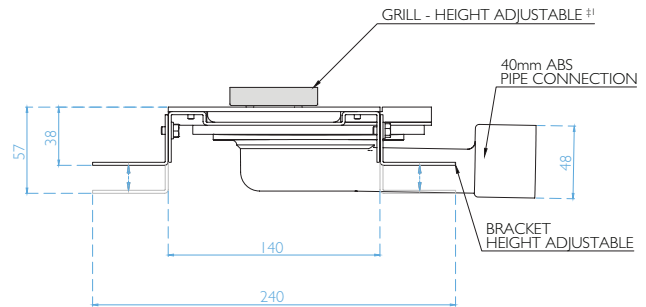

‡ See page 10 for details.

FLOOR GRILL WITH STANDARD BRACKETS

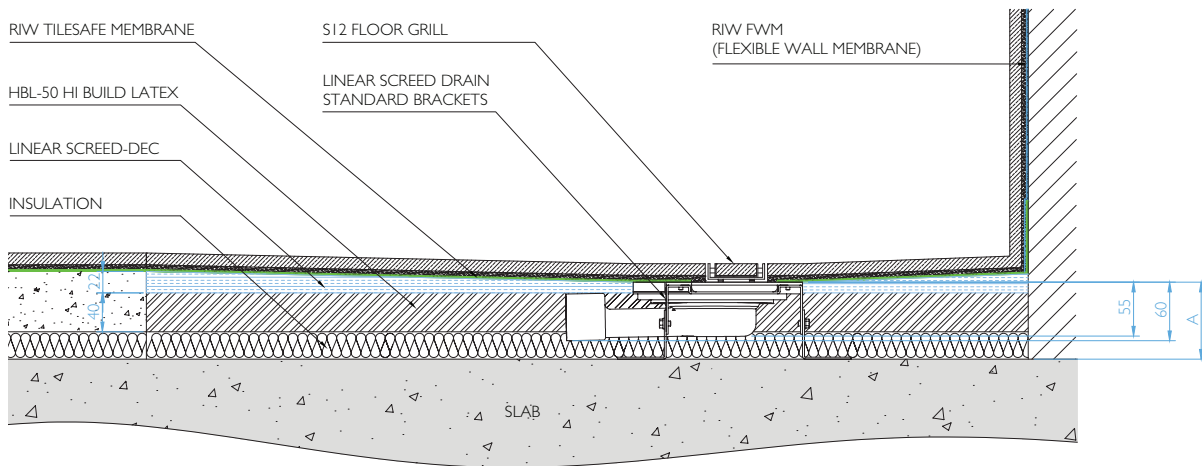

DIMENSION A : MIN. 55mm MAX. 88mm (Extension brackets available) drawn as 79mm.

FLOOR GRILL WITH EXTRA SHALLOW BRACKETS

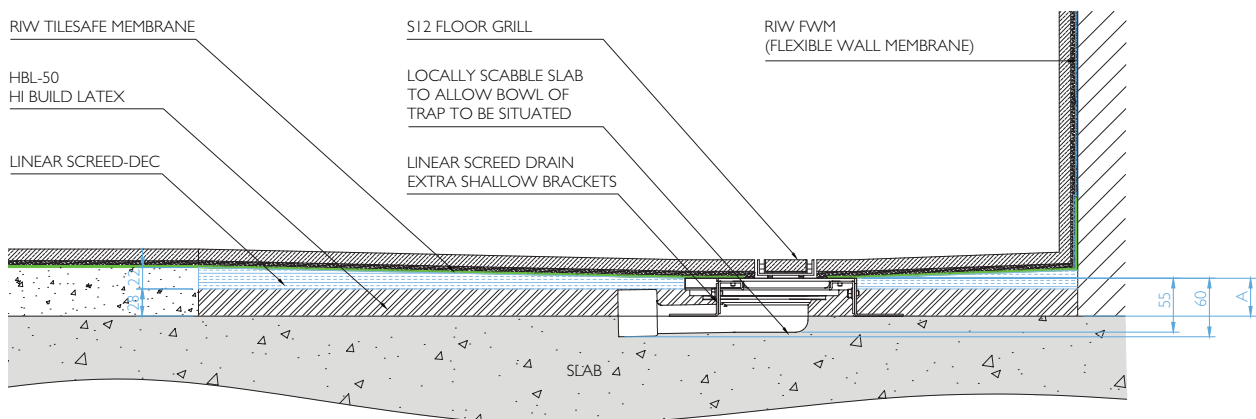

DIMENSION A : MIN. 38mm MAX. 57mm (Extension brackets available) drawn as 39mm.

TYPICAL DETAIL WITH WALL GRILL

SOLID FLOOR

- Use to create a **one-way fall**
- Minimum height 55mm with Standard Brackets
- Minimum height 38mm with Extra Shallow Brackets^{‡1}
- **O-SEAL** waterless trap
- 360° Rotatable waste outlet
- Centre, left and right handed waste position
- Flow rate up to 70 L/min^{‡2}
- Height adjustable brackets
- Grill lengths up to 2000mm

CENTRAL TRAP

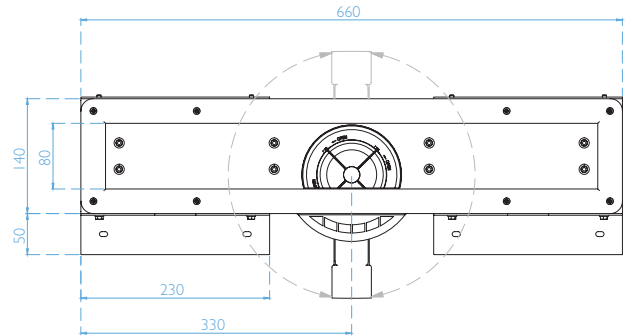

^{‡1} Requires drain outlet to be recessed into the slab, refer to drawing on pages 18 & 19.
^{‡2} See page 8 for full details.

LEFT HAND TRAP

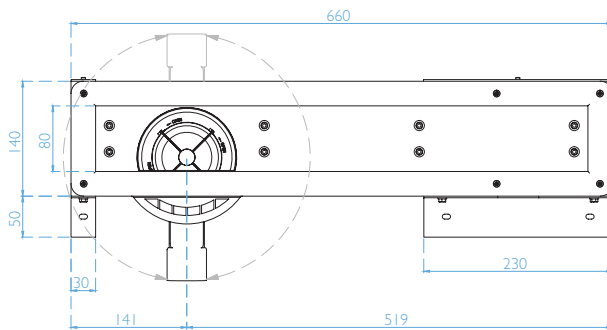

RIGHT HAND TRAP

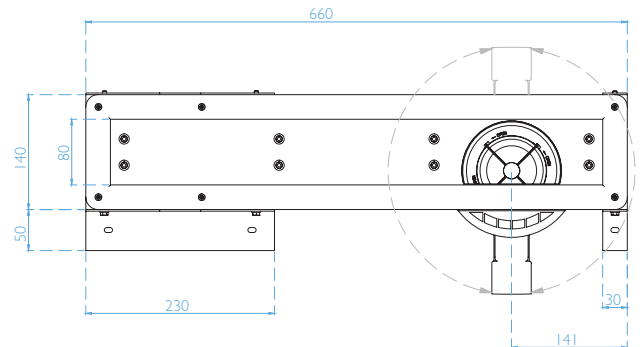

DOUBLE TRAP

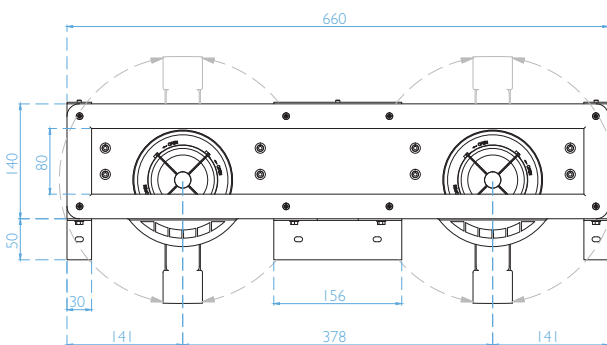

TRIPLE TRAP

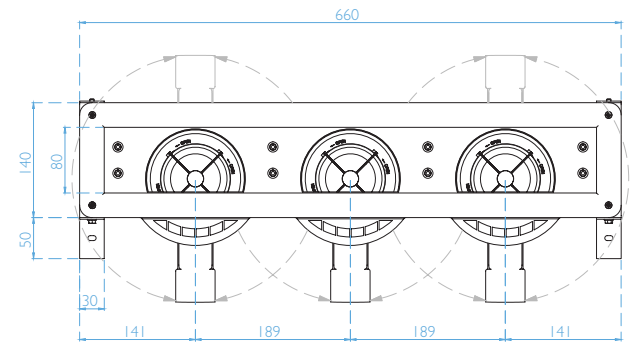

TYPICAL DETAIL WITH FLOOR GRILL

- Use to create a **two-way fall**
- Minimum height 55mm with Standard Brackets
- Minimum height 38mm with Extra Shallow Brackets ^{‡1}
- **Q-SEAL** waterless trap
- 360° Rotatable waste outlet
- Centre, left and right handed waste position
- Flow rate up to 70 L/min ^{‡2}
- Height adjustable brackets
- Grill lengths up to 2000mm

^{‡1} Requires drain outlet to be recessed into the slab, refer to drawing on pages 18 & 19.

^{‡2} See page 8 for full details.

CENTRAL TRAP

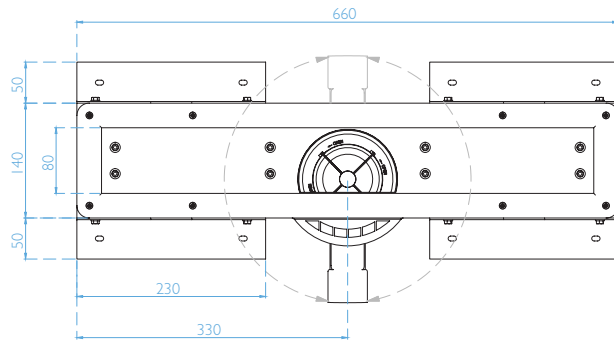

LEFT HAND TRAP

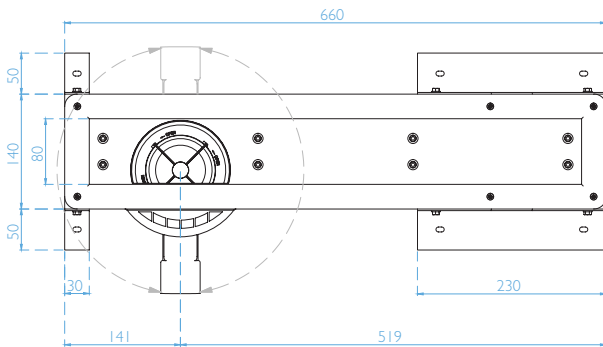

RIGHT HAND TRAP

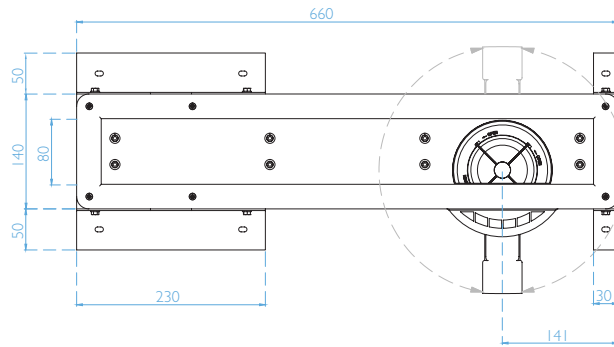

DOUBLE TRAP

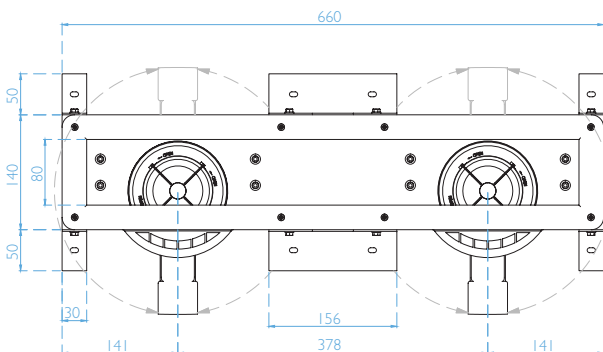

TRIPLE TRAP

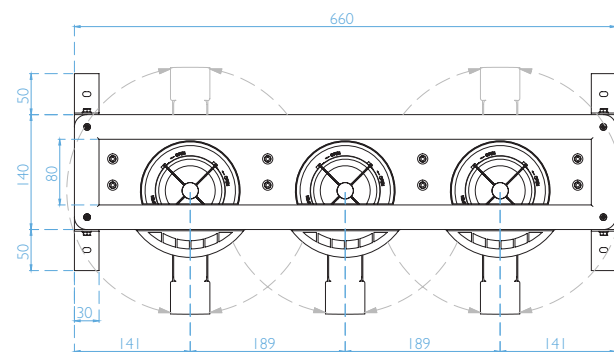

TECHNICAL SUPPORT

For technical assistance please contact our experienced technical department who will be happy to assist in the following:

- Project design
- Product specification
- CAD drawings
- Method statements

TECHNICAL SEMINARS

We are able to provide CPD based seminars designed to provide guidance on key wetroom design considerations such as;

- Design and layout
- Drainage
- Waterproofing
- Flow rates

For further information please contact our technical department.

TECHNICAL ADVICE

Our team of technical advisors are able to visit you to provide a professional advisory service and assist with project design and specification.

We are also able to attend site to provide technical support and assistance.

TECHNICAL ENQUIRIES

TEL: 0844 327 6002

Fax: 01256 765100

technical@ccl-wetrooms.co.uk

www.ccl-wetrooms.co.uk

CCL Specialist Supplies Ltd

Lodge Farm

Hook Road

North Wamborough

Hook

RG29 1HA



INSTALLATION

With over 30 years experience in the waterproofing industry, our involvement in a project from conception to completion ensures that quality is never compromised.

Our services include;

- Design and installation
- 10 Year Insured Installation guarantee
- On-site training

INSTALLATION ENQUIRIES

TEL: 0845 045 6001

Fax: 01256 765100

enquiries@wetroomsuk.co.uk

www.wetroomsuk.co.uk

Wetrooms UK Ltd

Lodge Farm, Hook Road

North Wamborough

Hook

RG29 1HA



part of
the CCL
group



PEACE OF MIND
GUARANTEED